

DOUBLE & KING SIZE

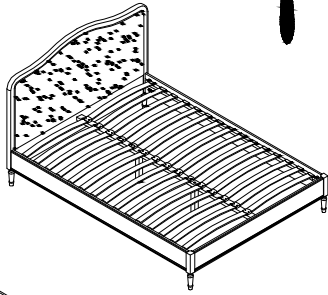

SUPER KING SIZE

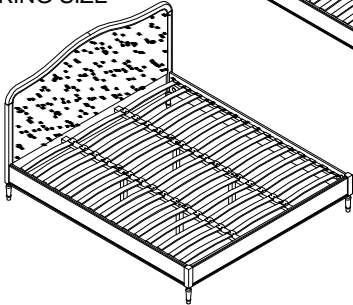

PLEASE READ this sheet prior to assembly to familiarise yourself with the various stages of construction.

Carefully open the pack supplied and check the contents against the parts and fittings check list. Do not destroy any of the packaging until you are certain that you have all the necessary parts for the assembly.

Please ensure that the packaging is disposed of in a safe and environmentally friendly way.

CAUTION: There are small components used in the construction of this unit. These loose items should be kept away from young children during assembly, to avoid the danger of choking.

IMPORTANT: BEFORE STARTING TO ASSEMBLE THE BED - PLEASE READ THESE INSTRUCTIONS CAREFULLY.

Parts Identification

SUPER KING SHOWN

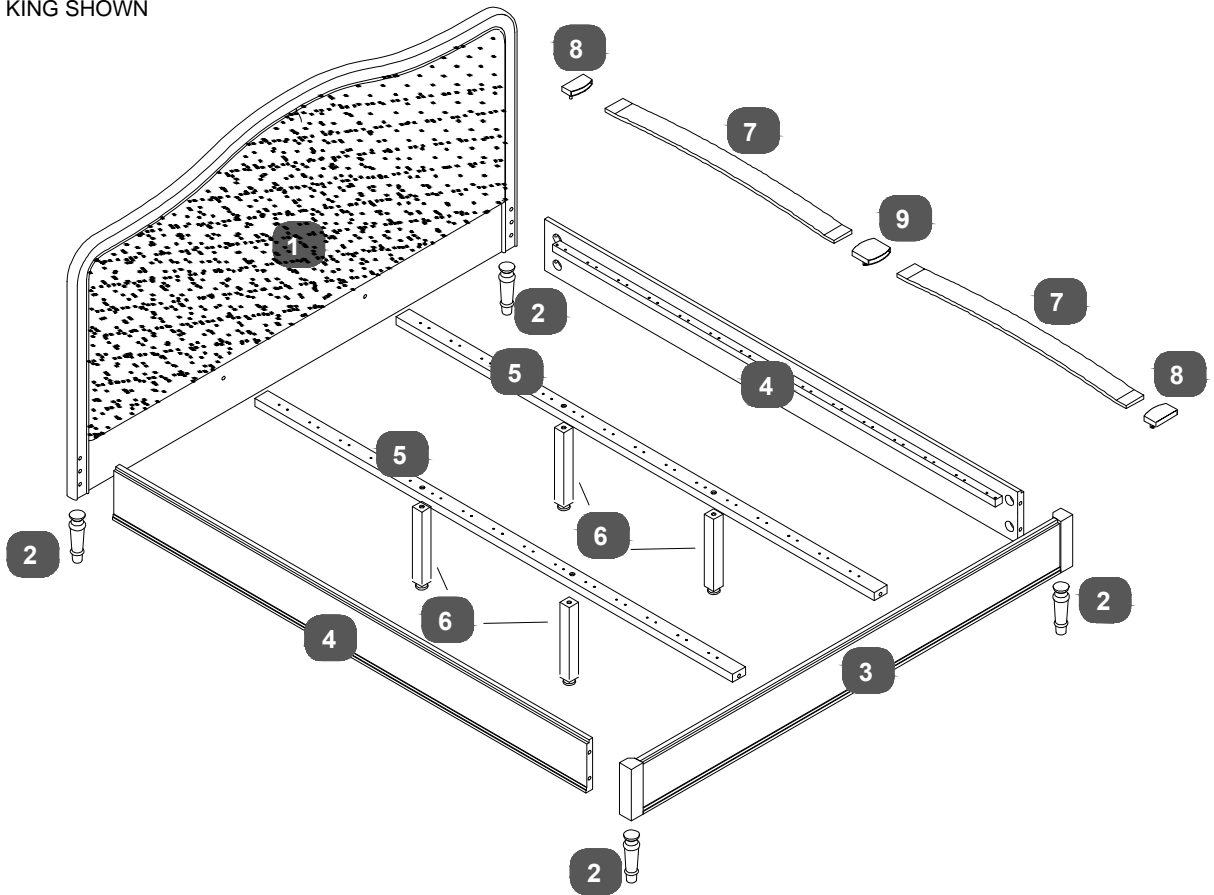







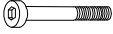

Parts Checklist

| Ref. | Description | Qty | Box | Ref. | Description | Qty | Box |
|------|-------------|-------------|-----|------|-------------------------|---------------------------|-----------|
| 1 | Headboard | 1 | 1 | 6 | Centre Rail Support Leg | Double / King/ Super king | 2 / 2 / 4 |
| 2 | Leg | 4 | 3 | 7 | Bentwood Slats | Double / King/ Super king | 28/30/45 |
| 3 | Footboard | 1 | 2 | 8 | Single Plastic Caps | Double / King/ Super king | 28/30/30 |
| 4 | Side Rail | 2 | 3 | 9 | Double Plastic Caps | Double / King/ Super king | 14/15/30 |
| 5 | Centre Rail | Double&King | 1 | | | | |
| | | Super King | 2 | | | | |

Fittings Checklist

HARDWARE NEEDED FOR BED ASSEMBLY

| Code | Description | | Qty | Box | Code | Description | | Qty | Box | | |
|------|---|---|-------------|-----|------------|------------------------|---|---|-------------|-----|---|
| A | Bolt (M8x35mm) for fitting centre rail support legs |  | Double&King | x2 | 3 | E | Spring washer for M8 bolts |  | Double&King | x10 | 3 |
| | | Super King | x4 | 3 | Super King | | | x12 | 3 | | |
| B | Threaded stud (M8x80mm) for fitting side rails (3&4) to headboard (1) and footboard (3) |  | Double&King | x10 | 3 | F | Half-moon Bracket |  | Double&King | x10 | 3 |
| | | Super King | x12 | 3 | Super King | | | x12 | 3 | | |
| C | Nut for M8 bolts |  | Double&King | x10 | 3 | G | Spanner for M8 bolts |  | | x1 | 3 |
| | | Super King | x12 | 3 | | | | | | | |
| D | Flat washer for M8 bolts |  | Double&King | x10 | 3 | H | Dowel (M10x40mm) |  | Double&King | x4 | 3 |
| | | Super King | x12 | 3 | Super King | | | x4 | 3 | | |
| | | | | | K | Allen key for M8 bolts |  | | x1 | 3 | |

Care & Maintenance

In the unlikely event of missing or damaged parts, please contact your retailer. Please have this guide at hand quoting the part code reference numbers shown when requesting spare or replacement parts.



General Hints & Tips

Please retain your assembly instruction and tools provided for future use. Periodically check that all bolts are still tight.



Approximate time to assemble this product

Bed Assembly

Stage
1

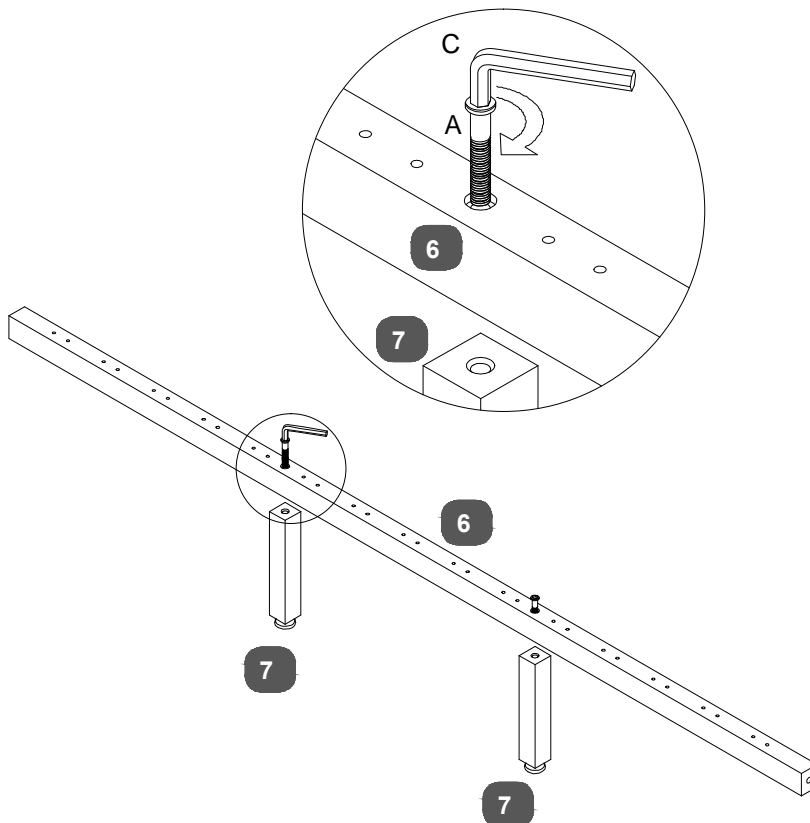

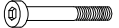

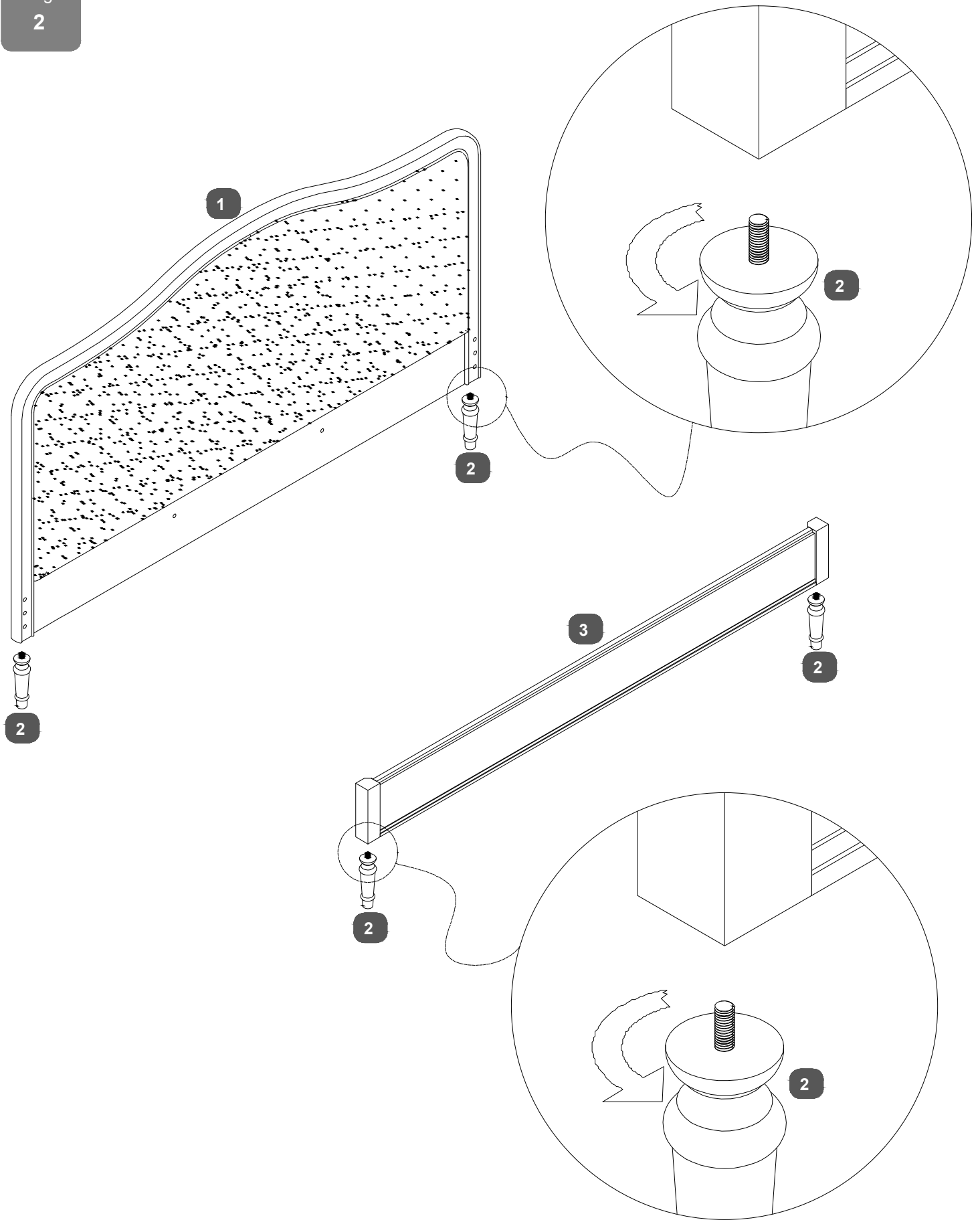

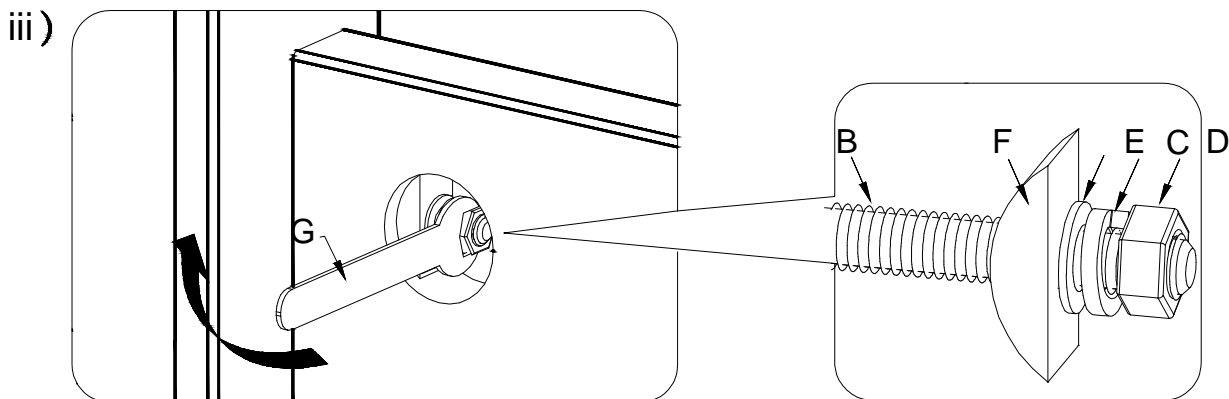
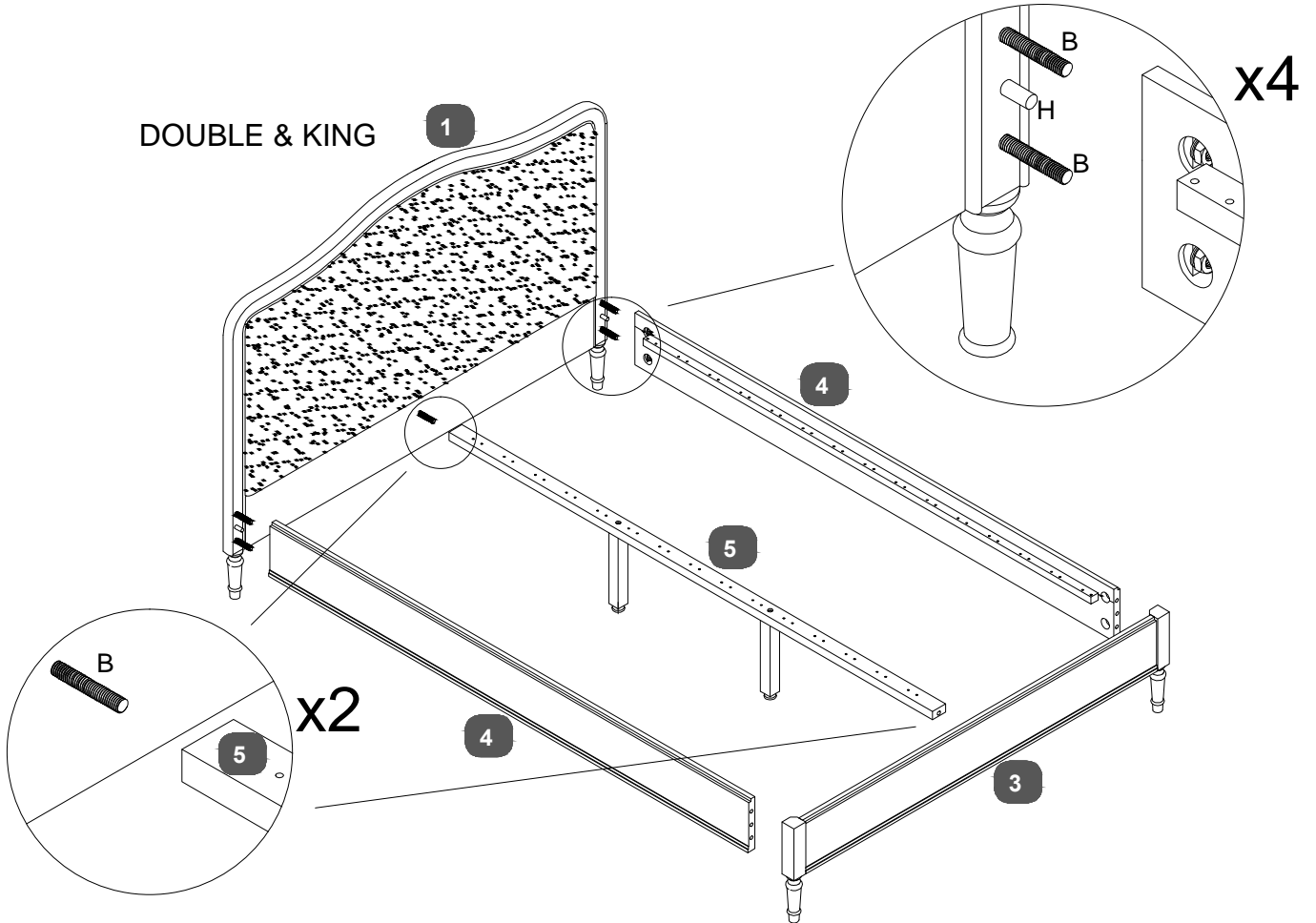
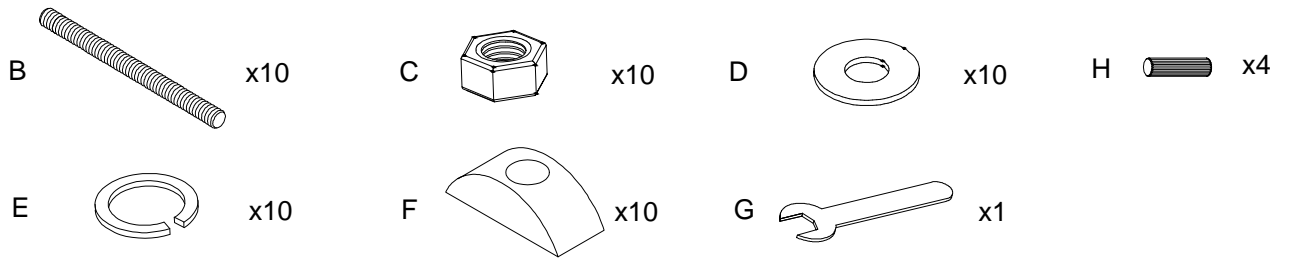

K x1  Double&King A x2
Super King A x4 

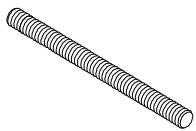

Stage
3

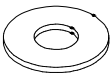

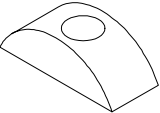
Stage
4

- B  x12
- C  x12
- D  x12
- H  x4
- E  x12
- F  x12
- G  x1

SUPER KING

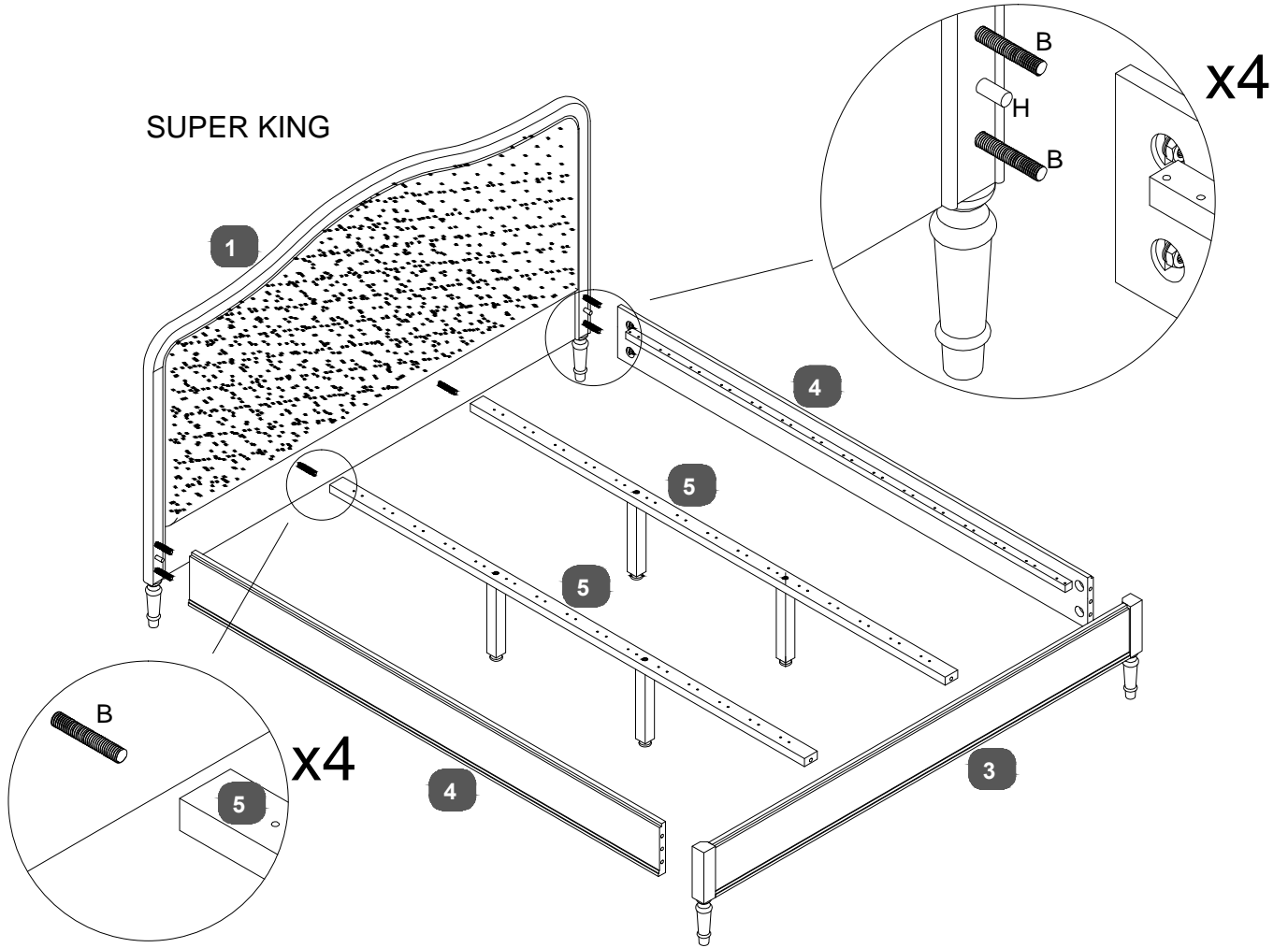

iii)

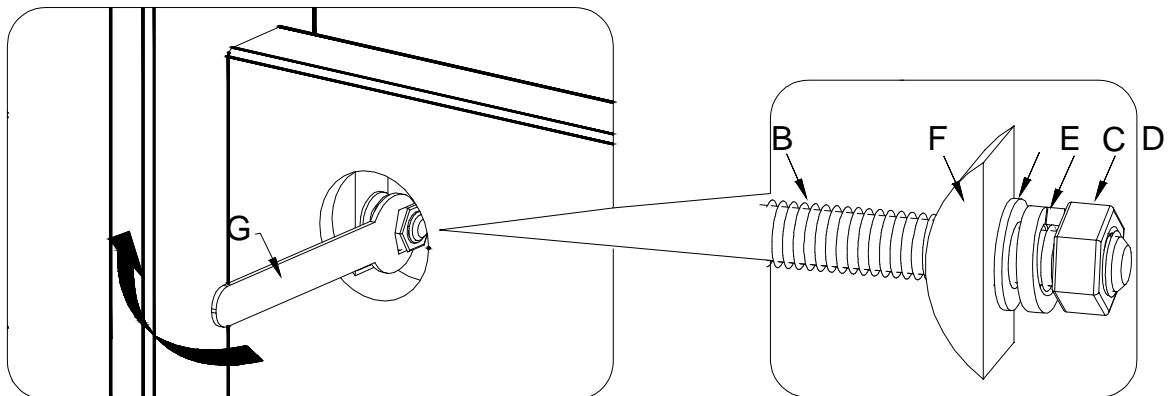

Stage
5

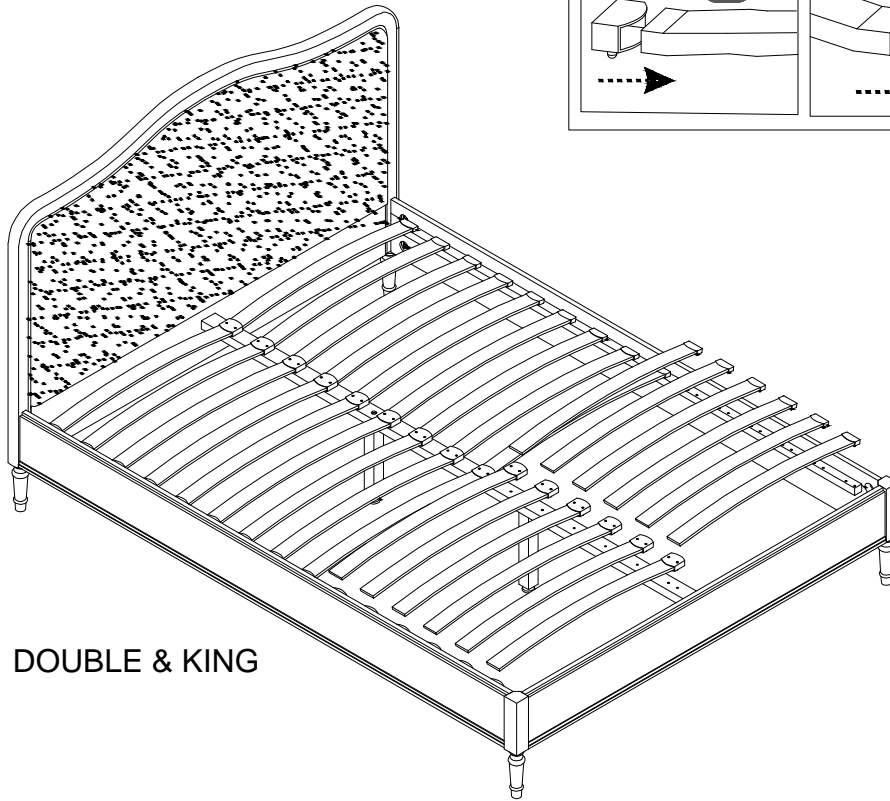
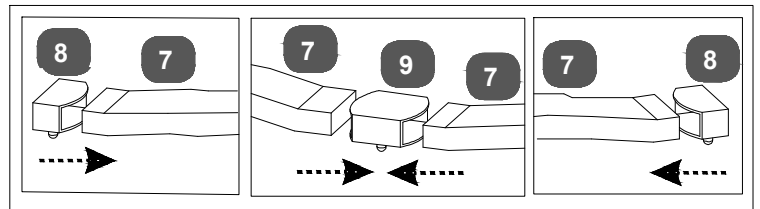

DOUBLE & KING

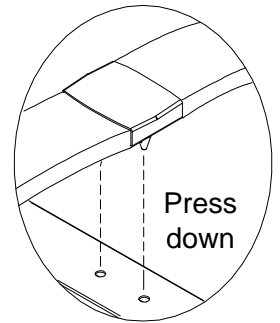
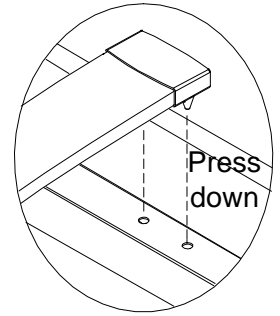

Stage
6

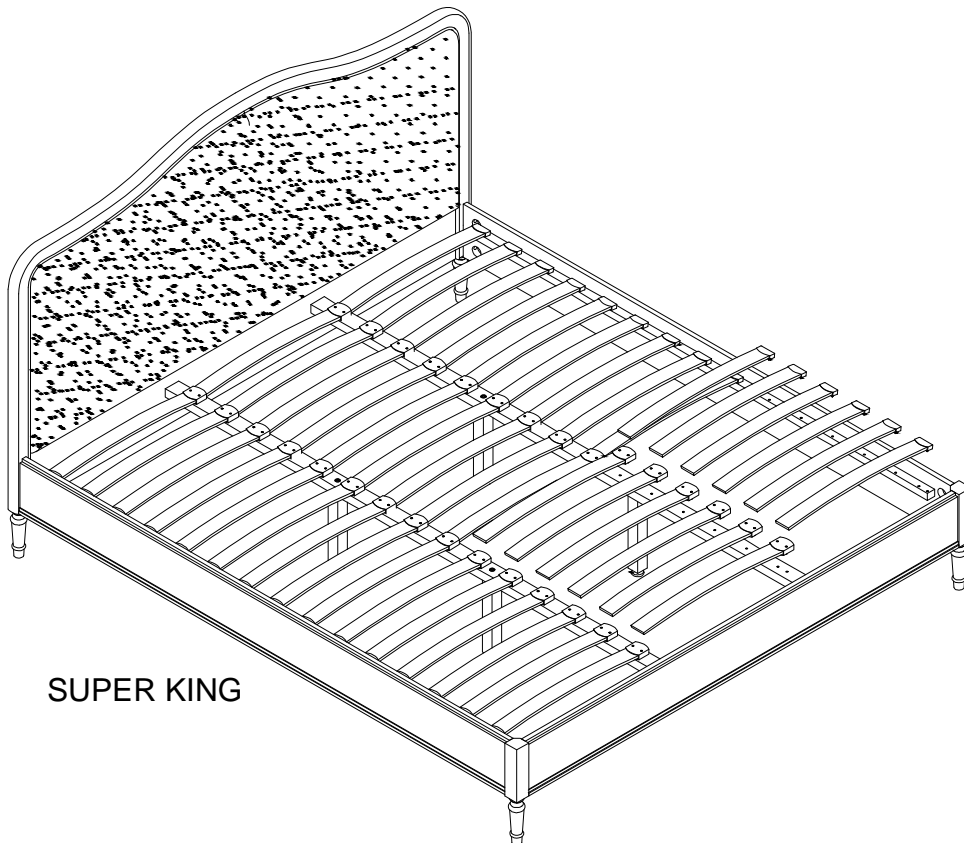
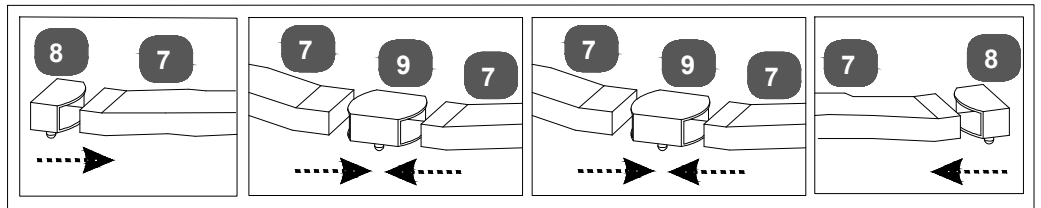

SUPER KING

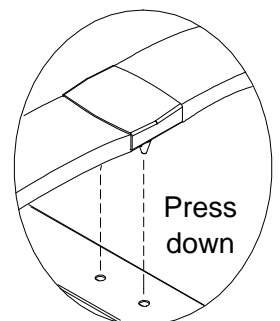
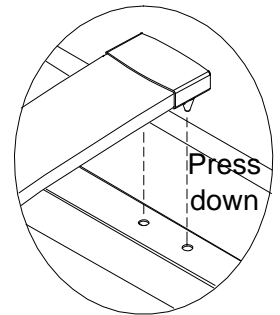

Technical Specifications

Overall Dimensions (LWH cm)

| | |
|-------------|-----------------|
| Double: | 201 x 144 x 116 |
| King: | 211 x 159 x 116 |
| Super King: | 213 x 189 x 116 |

Storage Dimensions (LWH cm)

| | |
|-------------|-------------|
| Double: | 194 x 136.5 |
| King: | 204 x 151.5 |
| Super King: | 204 x 181.5 |

Slats Dimensions (LWH cm)

| | |
|-------------|------------------|
| Double: | 67.5 x 5.3 x 0.9 |
| King: | 75.1 x 5.3 x 0.9 |
| Super King: | 60.0 x 5.3 x 0.9 |

Distance between slats 8 cm

